

# **A Review Paper on Underwater Data Transmission Using Li-Fi Technology**

**Amit A Deshmukh,**

*Assistant Professor,*

*Department of Electronics Engineering, Terna Engineering College, Nerul,  
Maharashtra, India*

**Abhishek Pawar, Roshan Suvarna, Sumit Nandkar, Archit Devendra**

*UG Student, Department of Electronics Engineering, Terna Engineering College, Nerul,  
Maharashtra, India.*

## **ABSTRACT:**

*In recent days, underwater communication has been used to keep track of obstacles and ocean species. Underwater communication cannot be used because in water the radio waves get absorbed. Li-Fi can be used underwater because light can penetrate deep water. In this project, we'll present a real-time video transmission using a Li-Fi (Light Fidelity) transmitter. The audio and video transmission achieve a maximum distance of 200m. The Li-Fi transmitter and receiver are used to analyze the performance and various conditions such as quality, intensity, and distance. The key advantages of Li-Fi are low power consumption and very high data rates. The aim of this project is to transfer text, audio, and image underwater using VLC technique*

**KEYWORDS:** Li-Fi, LED's, Underwater, Visible Light Communication (VLC).

## **INTRODUCTION:**

Light Fidelity (Li-Fi) is VLC, visible light communication technology developed by a research team at University of Edinburgh, including Professor Haas. Professor Harald Haas authored the term. Light Fidelity is modern wireless communication technology that empowers remote transmission of data using LED light. Light Fidelity depends on the novel ability of solid-state lighting systems to create 1s and 0s binary code with human-imperceptible LED illumination. Information may be obtained within the vicinity of visible light by means of electronic gadgets with photo-diodes. This means that light bulbs can bring not only light but wireless connection at same time anywhere where LED's are used. Generally speaking, Wi-Fi plays an efficient role in wireless data coverage within buildings, while using Li-Fi we will provide excellent density data coverage in particular locations without any radio interference issues. Li-Fi provides better latency, performance, accessibility and security than Wi-Fi, and under laboratory conditions has even reached extreme speeds greater than 1 Gbps. Li-Fi innovation has vast advantages contrasted with Wi-Fi. It takes out the adverse wellbeing impacts of using electromagnetic waves because it does not interfere with any electronic circuitry and is therefore safe and nonhazardous (Cailean et al., 2018). Given that light cannot pass through solid objects and walls, confidential information can be kept in an enclosed area (Wang et al., 2014). Li-Fi is also 1000 times denser than Wi-Fi. This is attributed to less light interference than radio interference. The output speed is also very high because African Journal of Engineering Research Vol. 8(1), pp. 1-9, February 2020 DOI: 10.30918/AJER.81.19.036 ISSN: 2354-2144 Review of high data density and bandwidth. As a result of these advantages, this technology is attractive for implementation in hospitals, clinics, banks and many more. There is an uncountable number of light bulbs worldwide which can be reestablished with LEDs for actual transmission of information, so availability is not an issue. This paper, therefore, further surveys implementations done with Li-Fi, challenges and further open areas

## **LITERATURE REVIEW:**

[1] In this Paper, Wiring Harnesses combine control and communication wires. Such a solution was successfully carried out and replaced the wiring harness for lamp, wiper and fan assembly in vehicles, this reduced the weight by 67%.

[2] With new 5G technology most of the concerns about 5G's supposed negative impact on health stem from its cell towers having such a different architecture than the ones supporting today's 3G and 4G cellular networks. Therefore, to achieve high data rate and meet the smart cities requirement, light fidelity (Li-Fi) is the best solution. Li-Fi can accommodate the huge number of users that are needed to connect everything to internet so called IOT.

[3] In this Paper, The visible light spectrum is operated by Li-Fi that is ten thousand times as much as the spectrum of radio waves. It uses visible light, rather than traditional radio waves, as a mode of transmission

[4] Sensors that monitor the human body include those that record respiration, blood pressure, and heartbeat. The PIC16F877A modifies it by converting it to digital form, which is then input into the Li-Fi module that communicates information in light form. The camera sensor's light is picked up by the receiver. The information is then visually displayed on the computer.

[5] The use of the visible light spectrum also means that Li-Fi has a smaller impact on the environment. As known, there was very little impact caused by visible *light spectrum* to other organisms such as plants, animals, and their ecosystem. So, as LIFI offers greater security, reduced power consumption, and *less environmental* impact, Li-Fi can be seen as a „greener“ yet more efficient technology.

[6] In this project, a small scale Li-Fi system that can be used to provide short-range tele-operational control of an underwater vehicle. Such control can either be provided from a diver operating in close proximity of the robot or via a communications relay from surface-based support.

[7] Li-Fi is the use of the visible light portion of the electro-magnetic spectrum to transmit information at very high speeds.

[8] In the system, the data is transferred at higher speed with the help of available light sources and there is no need for RF dependent technologies. Voice Activated Li-Fi Operated Surveillance where Li-Fi technology is employed as wireless medium to achieve machine movements according to the operator's voice using speech recognition algorithm.

[9] Voice guidance system using Li-Fi is an effective tool to guide normal and blind people. All we have to do is to program it into the chip and connect it to the illuminating device to guide a person entering the building to different regions through a pre-recorded audio using li-fi technology.

[10] The system is divided into four parts: a trolley portion, an invoicing server, a payment server, and a product id section. Each product has an RFID tag.reader may recognise each item added to the shopping cart, and list can be updated when one or more items are taken out.Trolley's LiFi establish connection with the server LiFi, which updates data.

### **AIM AND OBJECTIVES:**

- The main objective of the project is to provide an efficient, low cost, digitally controlled and fast data transfer technique.
- It can overcome the problem occurring in the communication (Interference and bandwidth).
- Data density can be increased and also it gives secure communication.
- In this project, we are transferring text, audio and image from transmitter end to receiver end underwater using Li- Fi.

## WORKING OF LIFI:

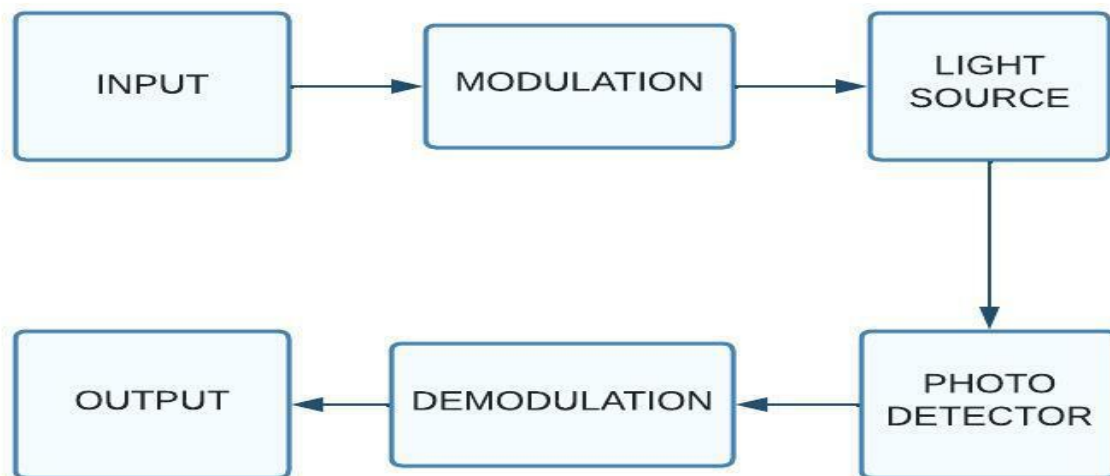

Li-Fi technology is based on the VLC system that uses visible light ranging from 400 THz (780 nm) to 800 THz (375 nm) as the optical carrier for data transmission (<https://seminarsprojects.net/Thread-li-fi-light-fidelity-the-future-technology-in-wireless-communication>; Haas, 2017). The team working on visible light connectivity 802.15.7 specification concluded the physical layer (PHY) project implementation and Media Access Control (MAC) for VLC in December 2011 (Gavrincea et al., 2014; I. Standard and I. C. Society, 2011). Li-Fi is installed on the downlink transmitter using white LED light bulbs. These devices are usually used for lighting using a constant current (Sarkar et al., 2015). Nevertheless, the optical quality can be varied at incredible speeds by small but rapid current variations. This optical current principle is used in Li-Fi wireless communication (Prakash and Agarwal, 2014). Data transmission is made possible by the invisible on-off action using binary codes. When an LED is switched on, a binary '1' is transmitted to a photo receiver and switching it off transmits a binary '0' to a photo receiver as shown in Figure 1. By changing the speed at which LEDs come on and off to produce different strings of 1s and 0s, information can be encrypted in the light. Modulation is too fast for humans to see (Sarkar et al., 2015). Using elevated speed, LEDs with sufficient multiplexing can attain data rates of more than 100 Mbps. The data rate of the VLC can be increased by parallel data transmission of LED arrays with each LED transmitting a different data stream (Karthika and Balakrishnan, 2015). Above figure shows that data coming from the internet goes into the Modulator-Demodulator (MODEM) where necessary modulation takes place. Once modulated, the information is then fed to the LED driver where driving current changes with the incoming streaming data. When the optical data is received, it is first changed into an electrical signal using a photo detector at the receiving end. After signal conditioning (amplification, processing and retrieval of binary data) data is fed into a laptop or other web empowered gadgets.

### LiFi Transmitter

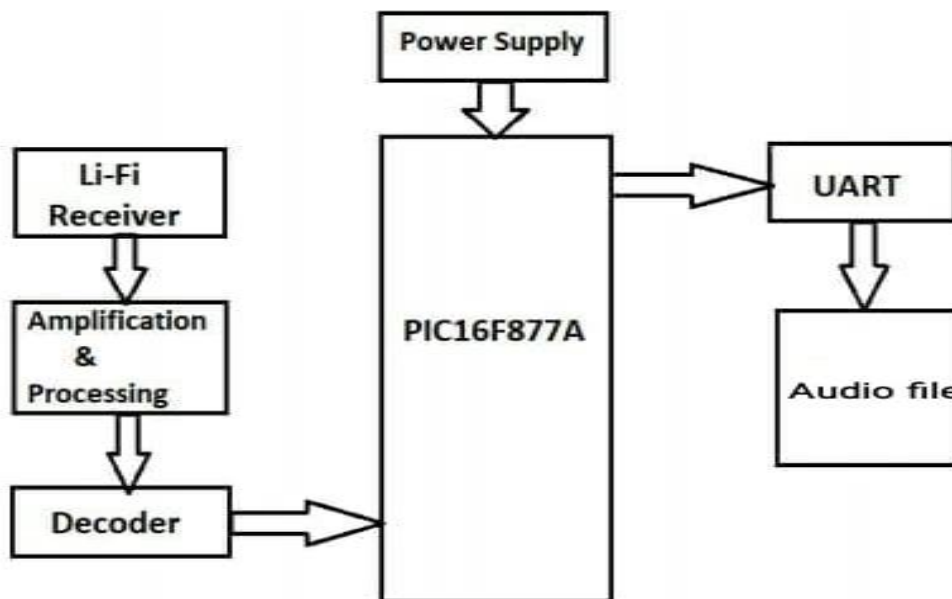
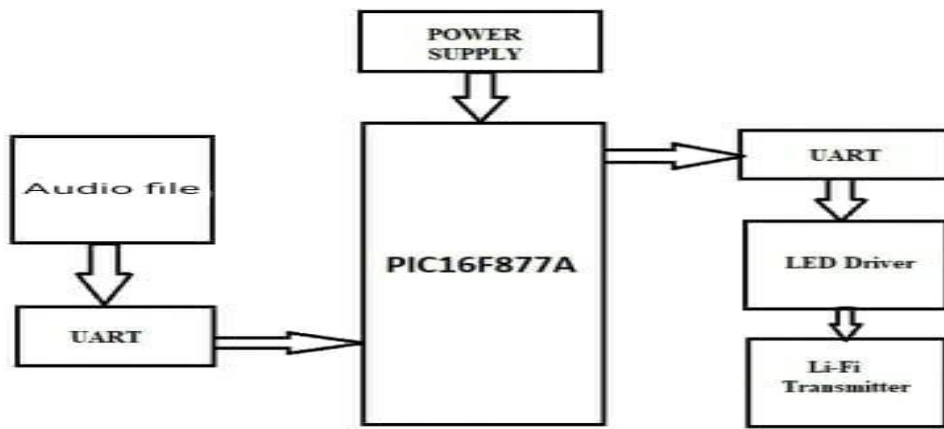

### LiFi Receiver

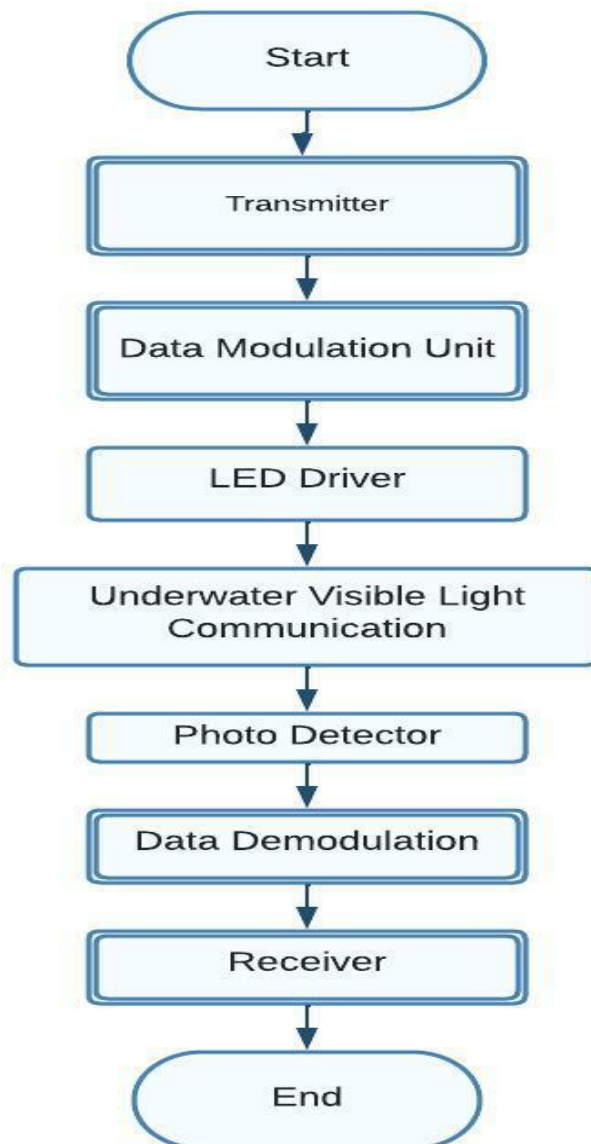

### Conclusion:

There are several options that can be investigated further. Every bulb might function as a Wi-Fi hotspot to transfer wireless data if this technology can be made usable, and we will get closer to a cleaner, greener, safer, and brighter future. Li-Fi is a notion that is now generating a lot of interest, not least because it might provide a true and highly effective replacement for radio-based wireless. The airways are getting increasingly congested as more people and their numerous devices use wireless internet, making it harder and harder to receive a dependable, high-speed connection. This could address problems like the lack of radio frequency spectrum and enable internet access in places where conventional radio-based wireless isn't permitted, like airplanes or hospitals. However, one drawback is that it only functions in a straight line of sight.

## References

- [1] *Wiring Harness Reduction In Automotive Using Lifi technology*, Natesan Palanivel, Tingsu Chen, 22 February 2018.
- [2] *Li-Fi Technology for Smart Cities*, Yaseein Soubhi Hussein, Ahmed Saeed Alabed, October 2020.
- [3] *Audio Transmission Through Lifi System*, M. Sharmila, M. Shrin Shifana, V.Theebica, V. Sangeethapriya, Mrs. M. Prathibha, April 2018
- [4] *Patient Monitoring in Hospital Management using Li-Fi*, S. Sudha, D Indumathy, A Lavanya, December 2016
- [5] *Environmental Impacts Review of Li-Fi and Wifi technologies*, C. W. D. Lumoindong, A. Muslim, B. M. Nasreddin and M. Galina, October 2018
- [6] Robert Codd-Downey and Michael Jenkin. “Wireless Teleoperation of an Underwater Robot using Li-Fi”, 2018.
- [7] *The Next Generation of Wireless Communication Using Li-Fi*, Yusuf Perwej, 2018.
- [8] Priyanka Tupe Waghmare, Parul Garg, “Voice Activated Li-Fi Operated Surveillance System”, 2015.
- [9] *Voice Guidance System Using LI-FI Technology*, Sabitha Gauni, Manimegalai.C.T, Kalimuthu.K , Murali Krishnan, 2018.
- [10] *An Intelligent Shopping Cart with Automatic Product Detection and Secure Payment System*, Sudipta Ranjan Subudhi Ponnalagu R. N., 2019.